



CHAMFERING MACHINE

PAC-12

PTC-36



Pintai Machinery is a specialized manufacturer of high precision samll grinders. In addition, we can design and manufacture various grinders according to customer's requirements. Currently we offer a series of equipment applicable for front process in tungsten carbide tool production, including tungsten carbide step-tool grinders, NC fully automatic chamfering machine, NC fully automatic carbide tool cutting machine, internal grinders, external grinders, polishing machines and cutting machines...etc.

NC CARBIDE CHAMFERING MACHINE PAC-12



Machine Features

- ▶ Adjustable workpiece taper for improving the machining accuracy.
- ▶ Double "V" slideways are hardened and high precision.
- ▶ The base is the best of resistance to vibration, low wear and long life time.
- ▶ Human-machine interfacing touch screen for easy operation.

Model / Specification	Unit	PAC-12
Clamping range of workpiece diameters	mm	Ø3-Ø25
Range of Chamfering	mm	Ø3-Ø12
Chamfering face	mm	Ø1-Ø25
Workpiece diameters	mm	Ø3-Ø12
Loading length	mm	L30-L125
Max travel of X axis	mm	150
Max travel of Y axis	mm	200
Min Feed unit X axis	-	Manual
Min Feed unit Y axis	mm	0.001
Work spindle speed	rpm	0-1200
Wheel spindle speed	rpm	0-6000
Wheel head motor	HP	2
Work head spindle motor	W	400
Y axis motor	KW	900
Machine dimensions(L*W*H)	mm	1100*1100*1600
Machine weight(approx.)	kg	650

▶ Standard Accessories

Flange Ø31.75mm
 SCHAUBLIN Collect Ø4 · Ø6(one each)
 Tool box and Kit
 Working light

Coolant device(standard)
 Fully cover
 Auto loading system
 Roller of hopper Ø4 · Ø6

▶ Optional Accessories

SCHAUBLIN collect Ø3 · Ø8 · Ø10 · Ø12 · Ø16 · Ø20
 Roller of hopper Ø8/Ø10 · Ø12/Ø16 · Ø3/Ø20

CARBIDE CHAMFERING MACHINE

PTC-36

Machine Features

- ▶ The machine is multi-function ,it can make various process with different formed grinding wheel.
- ▶ Simple construction, easy to repair and operating.
- ▶ Small dimensions to save space.
- ▶ High efficiency, production but save process time.
- ▶ High stability to improve quality.
- ▶ The machine has optional device of collector to reduce arrangement process.
- ▶ The machine is equipped with an manual lubricator for slideways lubrication.
- ▶ To use hydrophilic cutting oil for coolant grinding process.
- ▶ Suitable for tungsten carbide drill , milling ,to grinding OD and chamfering.
- ▶ Cycle time 6-12 sec/pc.

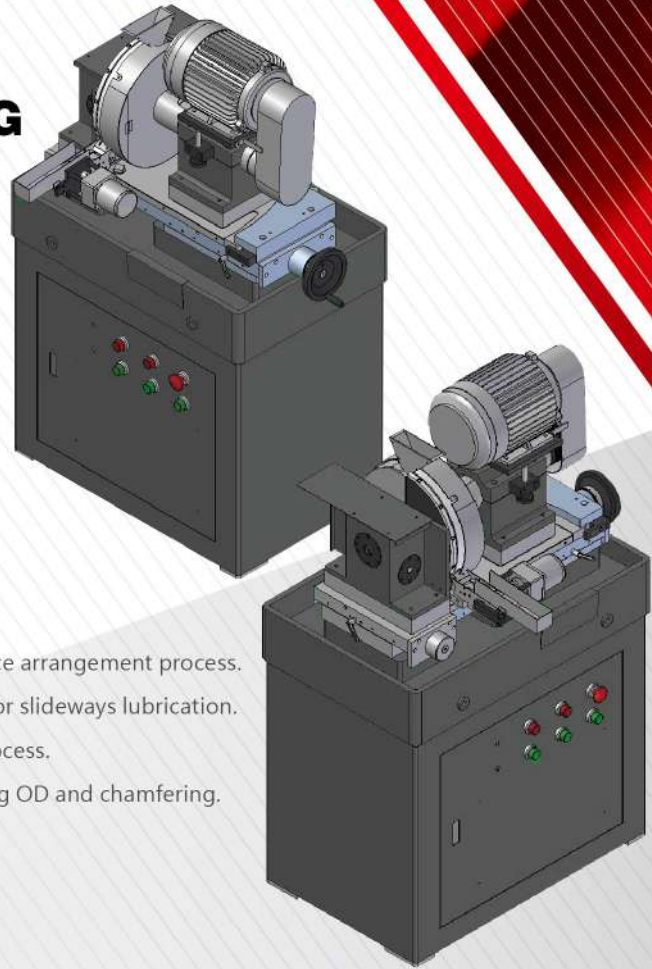

Model / Specification	Unit	PTC-36
Tool bar length	mm	L38-50 (customized for requirement)
Grinding diameters	mm	Ø3-Ø6
X axis travel	mm	150 (Adjusting by Hand-wheel)
Y axis travel	mm	20 (Adjusting by Hand-wheel)
Wheel dimensions (D*W*H)	mm	Ø200*20*Ø60
Grinding wheel motor	HP	3
Loading capacity	-	Max L70 , Ø3-Ø6 500pcs
Storage capacity	-	Max L200 , Ø3-Ø6 100pcs
Voltage	V	3P/220
Machine dimensions(L*W*H)	mm	880*750*1350

▶ Standard Accessories

Dial plate
Flat
Workpiece plate
Manual lubricator

Grinding wheel (Ø200mm*20mm*Ø60mm)

※ The loading / unloading system can be designed against workpieces' requirement.





PINTAI MACHINERY CO., LTD.

No.322, Lianchu Rd., Fengyuan Dist., Taichung, Taiwan 42082

Ver. 201802

 +886-4-2537 0951

 www.pintai-tw.com

 +886-4-2539 1801

 info@pintai-tw.com

PINTAI

倒角機系列

PAC-12

PTC-36



鑽鈦機械是一家專業生產小型研磨機，我們能夠根據客戶的需求開發出各種研磨機。目前提供鎢鋼刀具前製程一系列設備：NC全自動倒角機、NC全自動鎢鋼切斷機、鎢鋼段差研磨機、內徑研磨機、外徑研磨機、拋光機、切斷機...等

倒角機 系列 NC鎢鋼倒角機 PAC-12



機台特色

- ▶ 工件微小錐度可調，大大提高加工精度
- ▶ 使用高精度雙V硬軌鏟花床檯
- ▶ 耐震動、耗損低、壽命長，最佳之床檯型式
- ▶ 人機介面觸控式螢幕，操作簡易

型號/規格	單位	PAC-12
可夾持工件直徑	mm	Ø3-Ø25
導角範圍	mm	Ø3-Ø12
導角,修端面	mm	Ø1-Ø25
送料外徑	mm	Ø3-Ø12
送料長度	mm	L30-L125
最大行程 X 軸	mm	150
最大行程 Y 軸	mm	200
最小進給 X 軸	-	手動
最小進給 Y 軸	mm	0.001
工作主軸轉速	rpm	0-1200
砂輪主軸轉速	rpm	0-6000
砂輪主軸馬達	HP	2
工作主軸馬達	W	400
Y 軸馬達	KW	900
機械尺寸 (長*寬*高) (約)	mm	1100*1100*1600
機械重量(約)	kg	650

▶ 標準配件

法蘭本體 Ø31.75mm
SCHAUBLIN筒夾 Ø4、Ø6(各1只)
工具箱及其配件
工作燈

冷卻裝置(標準型)
全罩式板金
送收料裝置
料槽滾筒Ø4、Ø6

▶ 特殊配件

SCHAUBLIN筒夾Ø3、Ø8、Ø10、Ø12、Ø16、Ø20
料槽滾筒Ø8/Ø10、Ø12/Ø16、Ø3/Ø20

倒角機 系列 鎢鋼倒角機

PTC-36

機台特色

- ▶ 結構簡單，維修容易，操作容易
- ▶ 體積小，節省廠地
- ▶ 效率高，增加產能節省時間
- ▶ 穩定度高，提高產品品質
- ▶ 多用途機械，不同型式砂輪可作不同製程
- ▶ 可另裝配收料機構，減少整料時間
- ▶ 手動注油系統，延長滑座機構壽命
- ▶ 使用水性切削油進行切削冷卻研磨加工
- ▶ 適用於鎢鋼鑽頭銼刀研磨外徑與倒角
- ▶ 加工時間：6-12 sec/支

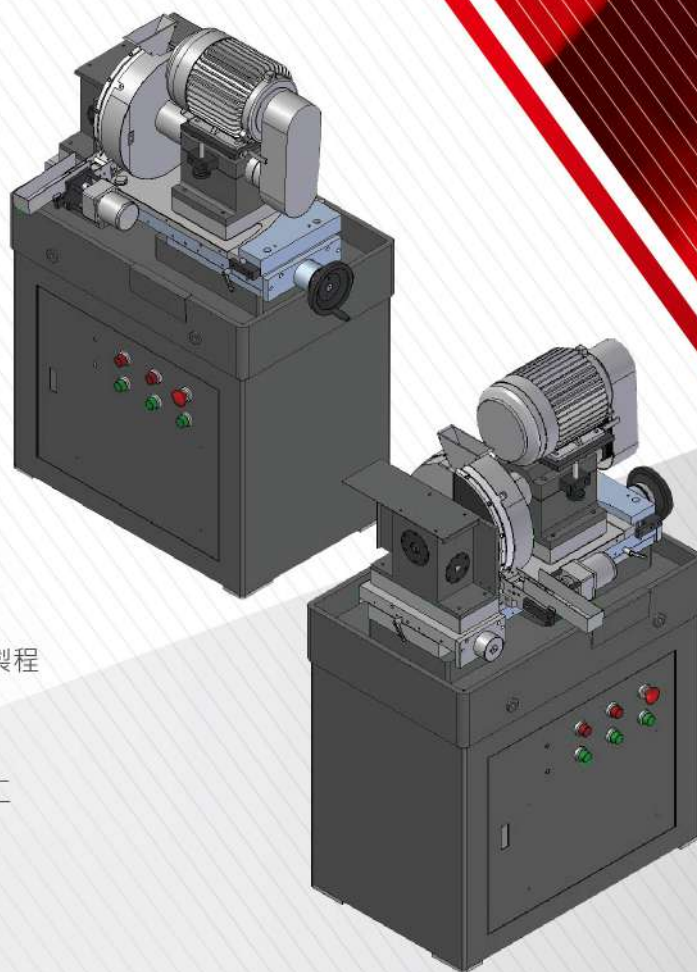

型號/規格	單位	PTC-36
可研磨棒材長度	mm	L38-50 (可依客戶工件需求做客製化)
可研磨外徑	mm	Ø3-Ø6
X軸行程	mm	150 (手輪調整)
Y軸行程	mm	20 (手輪調整)
砂輪尺寸 (外徑*厚度*內徑)	mm	Ø200*20*Ø60
砂輪馬達	HP	3
送料槽儲存量	-	Max L70 , Ø3-Ø6 可放 500pcs
收料槽儲存量	-	Max L200 , Ø3-Ø6 可放 100pcs
電壓	V	3P/220
機台尺寸 (長*寬*高) (約)	mm	880*750*1350

▶ 標準配件

針盤
壓板
膠盤
手動注油系統

砂輪(Ø200mm*20mm*Ø60mm)

※可依照工件需求搭載送收料裝置。

The logo for PINTAI, featuring the word "PINTAI" in a bold, black, sans-serif font. A red swoosh underline is positioned under the "I".

Ver. 201802

鑽鈦機械有限公司
420 台中市豐原區鎌村路322號



+886-4-2537 0951



www.pintai-tw.com



+886-4-2539 1801



info@pintai-tw.com